

# DIGITAL PIANO

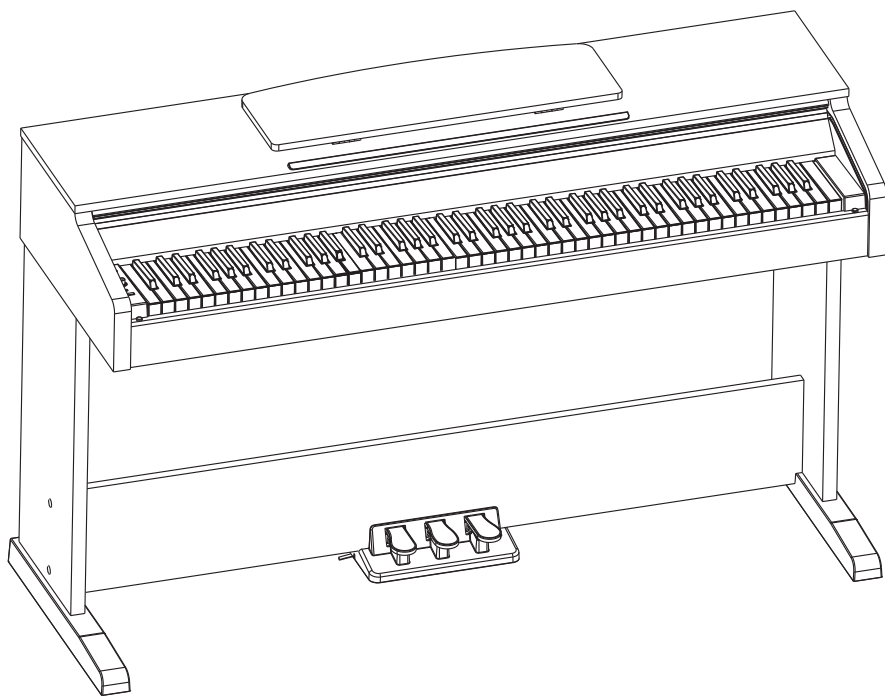

## Owner's Manual

## THE FCC REGULATION WARNING (for USA)

This equipment has been tested and found to comply with the limits for a Class B digital device, pursuant to Part 15 of the FCC Rules.

These limits are designed to provide reasonable protection against harmful interference in a residential installation. This equipment generates, uses, and can radiate radio frequency energy and, if not installed and used in accordance with the instructions, may cause harmful interference to radio communications. However, there is no guarantee that interference will not occur in a particular installation. If this equipment does cause harmful interference to radio or television reception, which can be determined by turning the equipment off and on, the user is encouraged to try to correct the interference by one or more of the following measures:

- Reorient or relocate the receiving antenna.
- Increase the separation between the equipment and receiver.
- Connect the equipment into an outlet on a circuit different from that to which the receiver is connected.
- Consult the dealer or an experienced radio/TV technician for help.

Unauthorized changes or modification to this system can void the user's authority to operate this equipment.

### CAUTION

The normal function of the product may be disturbed by Strong Electro Magnetic Interference. If so, simply reset the product to resume normal operation by following the owner's manual. In case the function could not resume, please use the product in other location.

## PRECAUTIONS

### PLEASE READ CAREFULLY BEFORE PROCEEDING

Please keep this manual in a safe place for future reference.

#### Power Supply

Please connect the designated AC adaptor to an AC outlet of the correct voltage.

Do not connect it to an AC outlet of voltage other than that for which your instrument is intended.

Unplug the AC power adaptor when not using the instrument, or during electrical storms.

#### Connections

Before connecting the instrument to other devices, turn off the power to all units. This will help prevent malfunction and / or damage to other devices.

#### Location

Do not expose the instrument to the following conditions to avoid deformation, discoloration, or more serious damage:

- Direct sunlight
- Extreme temperature or humidity
- Excessive dusty or dirty location
- Strong vibrations or shocks
- Close to magnetic fields

#### Interference with other electrical devices

Radios and televisions placed nearby may experience reception interference. Operate this unit at a suitable distance from radios and televisions.

#### Cleaning

Clean only with a soft, dry cloth.

Do not use paint thinners, solvents, cleaning fluids, or chemical-impregnated wiping cloths.

#### Handling

Do not apply excessive force to the switches or controls.

Do not let paper, metallic, or other objects into the instrument. If this happens, unplug the AC adaptor from the wall outlet. Then have the instrument inspected by qualified service personnel.

Disconnect all cables before moving the instrument.

## Panel Description

Front Panel.....	4
Rear Panel.....	5

## Setup

Part List.....	6
Setup Guide.....	7
Power Supply.....	8

## Connections

Connecting a pair of Headphones.....	9
Connecting an Audio Equipment.....	9
Connecting an MP3/CD.....	9
Connecting a Computer.....	9

<b>Listening to the Demo song .....</b>	<b>10</b>
---	-----------

<b>Adjusting the Volume.....</b>	<b>10</b>
----------------------------------	-----------

## Playing Voices

Selecting a Voice.....	10
Playing two Voice Simultaneously.....	11
Playing a Lower Voice.....	11
Playing Voice Demo.....	11
Touch Response.....	11

## Digital Effects

Reverb and Chorus Effect .....	12
EQ Effect.....	12

<b>Metronome.....</b>	<b>12</b>
-----------------------	-----------

<b>Tempo.....</b>	<b>13</b>
-------------------	-----------

<b>Beep Tone.....</b>	<b>13</b>
-----------------------	-----------

<b>Troubleshooting.....</b>	<b>14</b>
-----------------------------	-----------

<b>Specifications.....</b>	<b>14</b>
----------------------------	-----------

## Appendices

Voice List.....	14
MIDI Implementation List chart.....	15

# Panel Description

## Front Panel

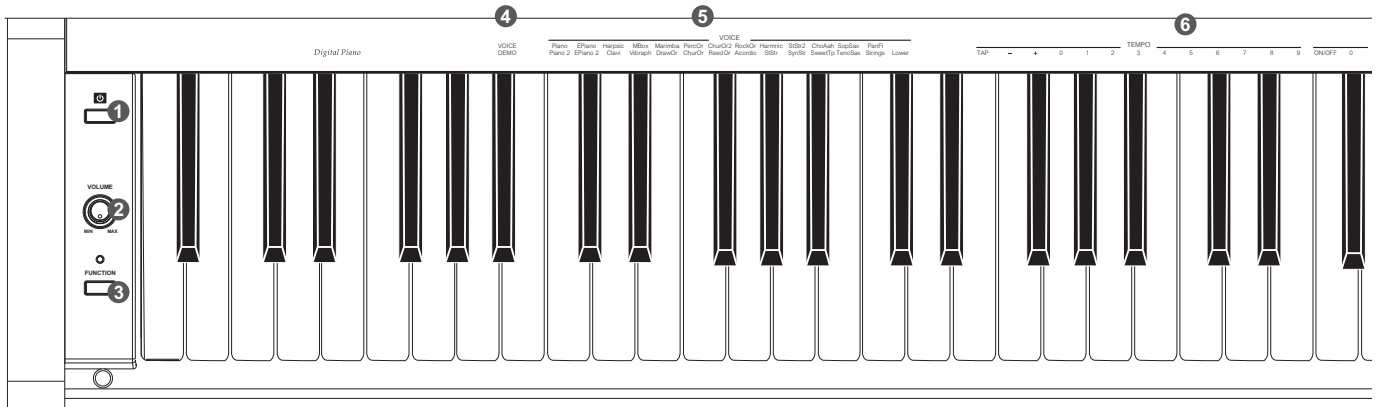

### 1. POWER ON / OFF

Turn the power ON or OFF.

### 2. MASTER VOLUME

Adjust the master volume.

### 3. FUNCTION Button

Hold down this button and press the special keys to realize different functions.

### 4. VOICE DEMO Key

Hold down the [ FUNCTION ] button and press the key to start/stop the voice demo playing.

### 5. VOICE SELECT Key

Hold down the [ FUNCTION ] button and press the key to select a voice.

### 6. TEMPO ADJUST Key

Hold down the [ FUNCTION ] button and press the key to adjust the current tempo.

### 7. SUSTAIN Pedal

Step on the sustain pedal, all notes played on the keyboard would have a longer sustain.

### 8. SOSTENUTO Pedal

Step on the sostenuto pedal, the notes played before you step on would have a sustain effect.

### 9. SOFT Pedal

Step on the soft pedal, all notes played on the keyboard would have a softer effect.

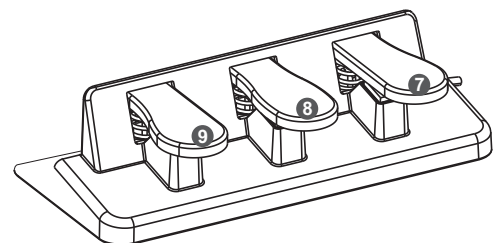

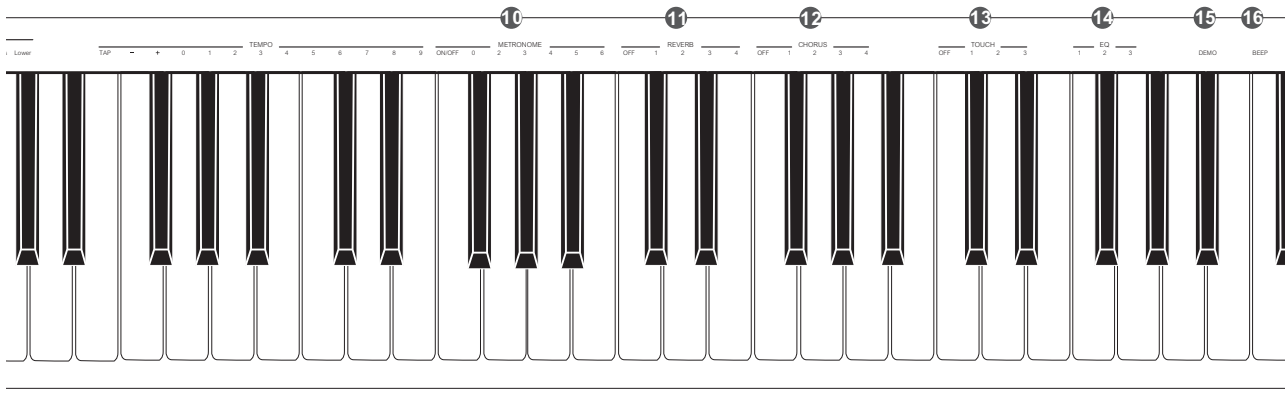

## 10. METRONOME Key

Hold down the [ FUNCTION ] button and press the [ ON/OFF ] key to turn the metronome ON or OFF. Hold down the [ FUNCTION ] button and press the other key to select the time signature.

## 11. REVERB Key

Hold down the [ FUNCTION ] button and press the [ ON/OFF ] key to turn reverb effect ON or OFF. Hold down the [ FUNCTION ] button and press the other key to select the reverb type.

## 12. CHORUS Key

Hold down the [ FUNCTION ] button and press the [ ON/OFF ] key to turn chorus effect ON or OFF. Hold down the [ FUNCTION ] button and press the other key to select the chorus type.

## 13. TOUCH Key

Hold down the [ FUNCTION ] button and press the key to select different touch response level.

## 14. EQ Key

Hold down the [ FUNCTION ] button and press the key to select the EQ type.

## 15. DEMO Key

Hold down the [ FUNCTION ] button and press the key to start or stop playing the demo song.

## 16. BEEP Key

Hold down the [ FUNCTION ] button and press the key to turn the prompt tone ON or OFF.

## Rear Panel

### 17. USB Jack

Connect to a computer.

### 18. AUX OUT Jack

Connect the audio equipment.

### 19. AUX IN Jack

Connect an external sound source, such as an MP3 or CD player.

### 20. DC IN Jack

Connect the DC 12V power adaptor.

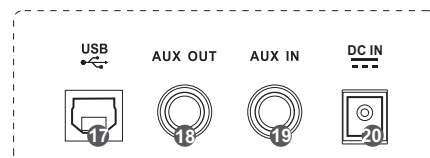

# Setup

This section contains information about setting up your instrument and preparing to play. Please go through this section carefully before turning the power on.

## Part List

Before you proceeding to assemble the stand, get a Philip's screwdriver (not supplied).  
Make sure you have the following parts, which are supplied into package.

1.	Piano Cabinet
2.	Support Plate
3.	Pedal Box
4.	Left Feet edge board
5.	Right Feet edge board
6.	Handle tighten Screw(4)
7.	Screw CM6*50mm(4)
8.	Screw Cover(4 pcs)
9.	Pedal Cable
10.	Nut M6(4)

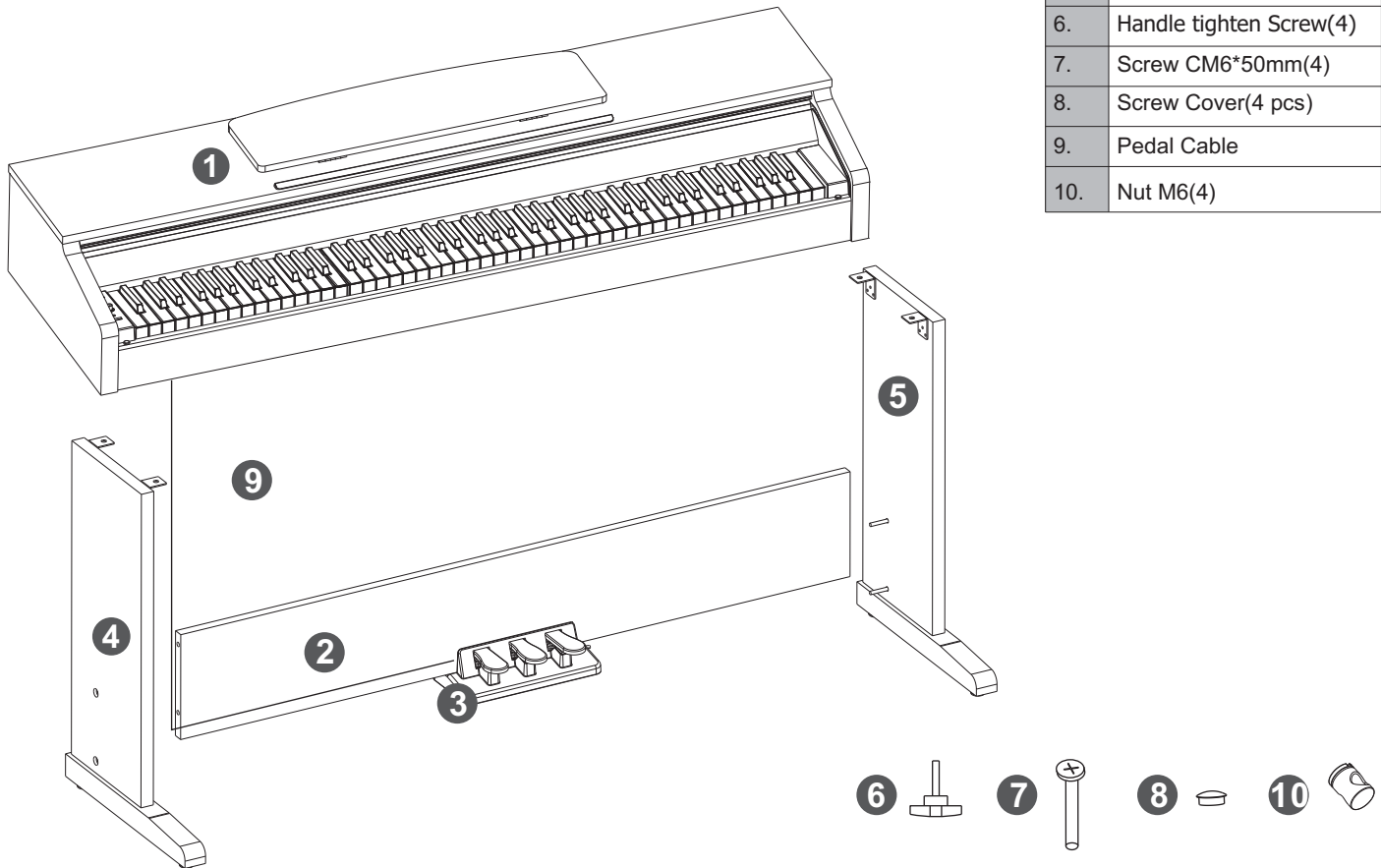

## Setup Guide

- A.** Fix and well tighten the left and right side boards [4] & [5] to the Support Plate[2] with Screw CM6\*50mm(4pcs) [7] and nut M6 [10] . The screw Cover(4pcs) [8] above Screw CM6\*50mm (4pcs) [7].

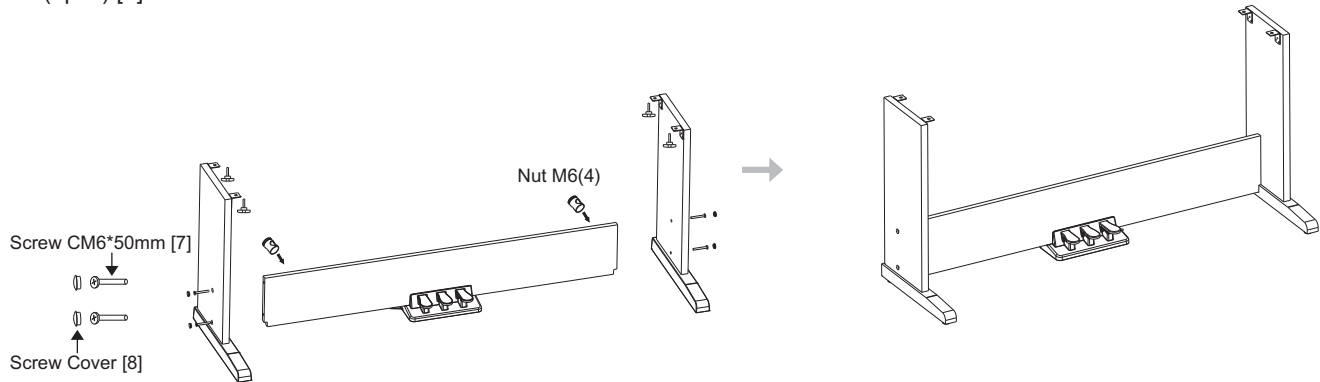

- B.** Put the piano cabinet [1] on the stand, fix it with Handle tighten Screw(4) .

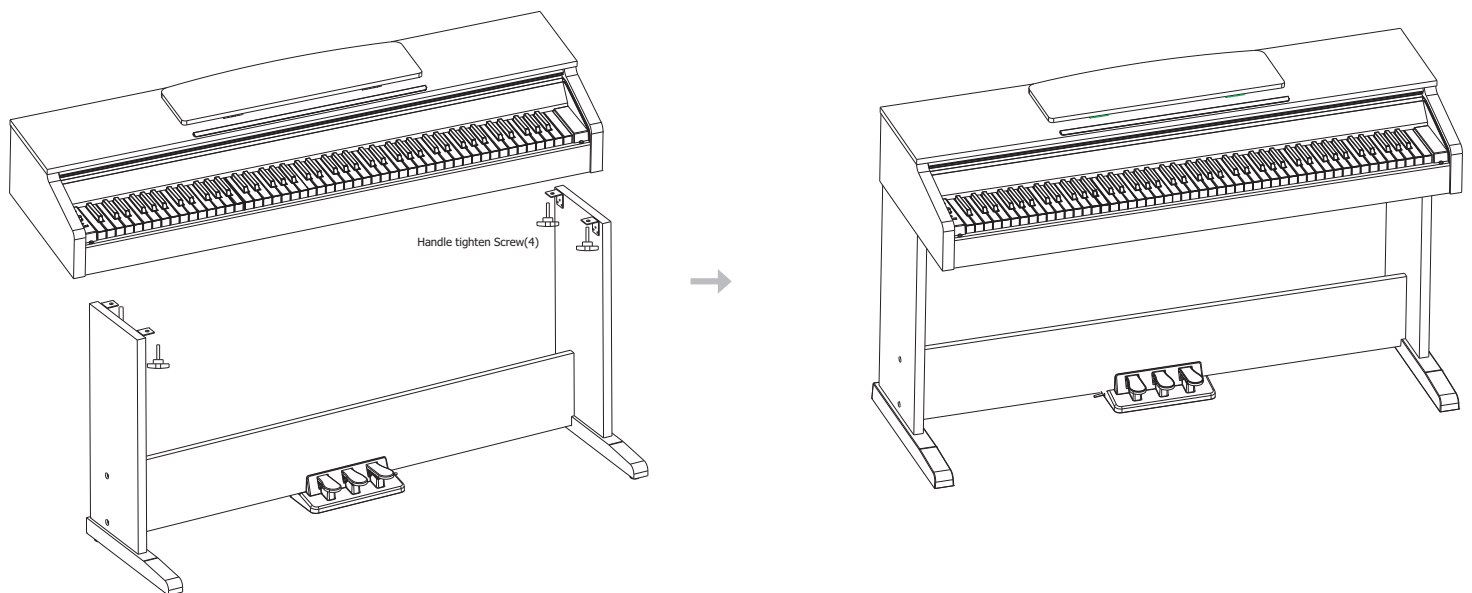

- C.** Insert the pedal cable [9] into the proper socket of the cabinet [1].

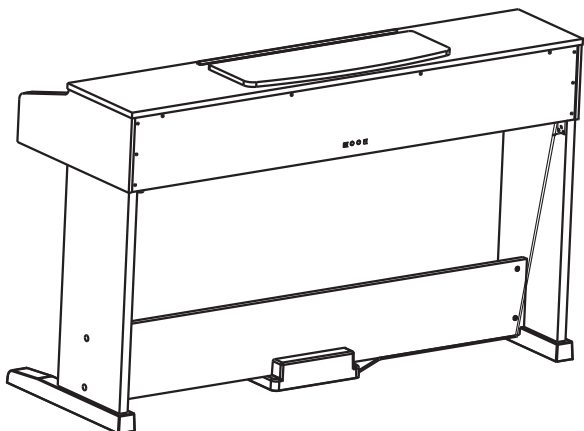

# Setup

## Power Supply

1. Make sure that the piano is turned off. Before you switch your piano on or off, turn down the volume of piano and any connected audio equipments first.
2. Connect the AC adaptor to the power supply jack.
3. Plug the AC adaptor into an AC outlet.
4. Press the [POWER] button, the LED display will lights up, that indicates the piano has powered on.
5. If you are ready to turn off the piano, press the [ POWER ] switch again.

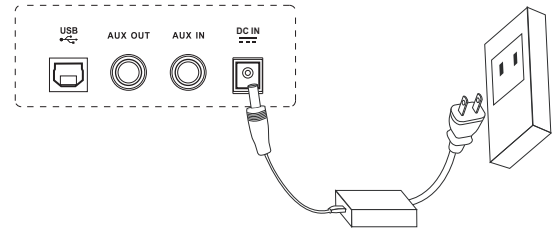

### Note:

1. In order to save energy, we have designed the “Automatic Shutdown” function to the piano. With this function, the piano will shutdown automatically when you have left it idle for more than 30 minutes. If you don't need this feature, just press and hold the [A0] key (the 1st key) and turn it on.
2. When the piano is not in use or during thunderstorm, please disconnect the power for safety purpose.

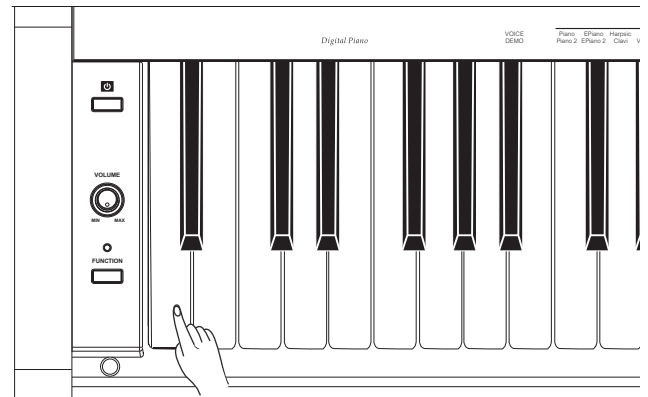



## Connecting a pair of Headphones

A standard pair of stereo headphones can be plugged in here for private practice or late-night playing.

**Jack1:** When a pair of headphones is plugged into the Jack 1, the sound can be heard from headphones and speakers of the instrument.

**Jack2:** When a pair of headphones is plugged into Jack 2, the internal stereo speaker system is automatically shut off. The sound can be heard from headphones.

**Note:**

Do not listen with the headphones at high volume for long periods of time. Doing so may cause hearing loss.

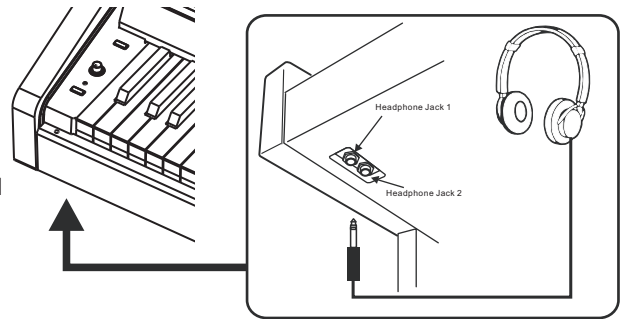

## Connecting an Audio Equipment

The rear-panel AUX OUT jack delivers the output of the instrument for connection to a keyboard amplifier, stereo sound system, a mixing console, or tape recorder. Use an audio cord to plug into the AUX OUT jack located on the rear board then plug the other end of the cord into AUX IN of the amplifier.

**Note:**

To avoid damaging the speakers, please ensure that the volume has been set to the minimum level before connecting the power and other devices.

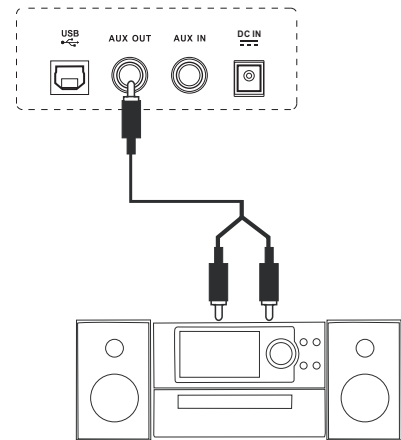

## Connecting an MP3/CD Player

Connect the audio output of an MP3/CD player or other audio source to the stereo AUX IN jack on the rear panel. The input signal is mixed with the piano signal, allowing you to play along.

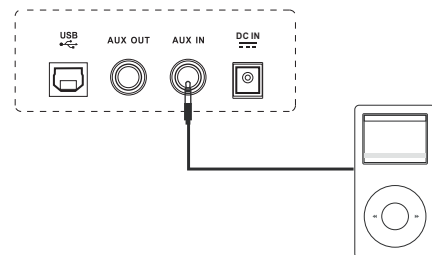

## Connecting a Computer

Connect PC or other USB host devices that support USB audio. For devices with USB cable, you can simply connect the MIDI/USB converter to your USB connector on the device and plug the USB cable into the piano, after the driver is installed and initialization is finished, you can choose USB Audio Device in the device menu of the software to transfer midi data.

**Note:**

Do not select USB audio device in both of input and output setting together, otherwise the sound overlaps.

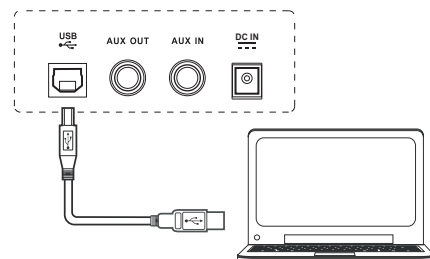

# Listening to the Demo song

While holding down the [ FUNCTION ] button, press DEMO key to start the demo song playing. Press it again to stop playing.

The keyboard would be disabled when the demo song is playing.

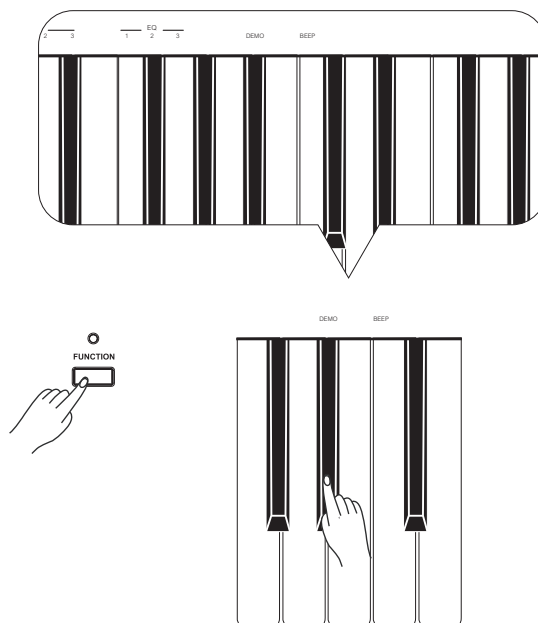

## Adjusting the Volume

Move the [ VOLUME ] knob rightwards, the volume increases. Moving it leftwards will turn the volume down.



## Playing Voices

### Selecting a Voice

The instrument features 26 exceptionally realistic voices for you to choose. Please refer to Voice List.

While holding down the [ FUNCTION ] button, press corresponding key in voice selecting area to select the voice you want. Now, You can play the keyboard and listen to the wonderful voice.

#### Note:

1. While changing a voice, pay attention to the rules: While holding down the [ FUNCTION ] button, and press the same key again, the voice will be changed between the upper and lower key. When the upper/lower voice is on, and then you press another voice key, the corresponding upper/lower voice will be selected.
2. While voice is selected, the dual voice and lower voice will be turned off automatically.

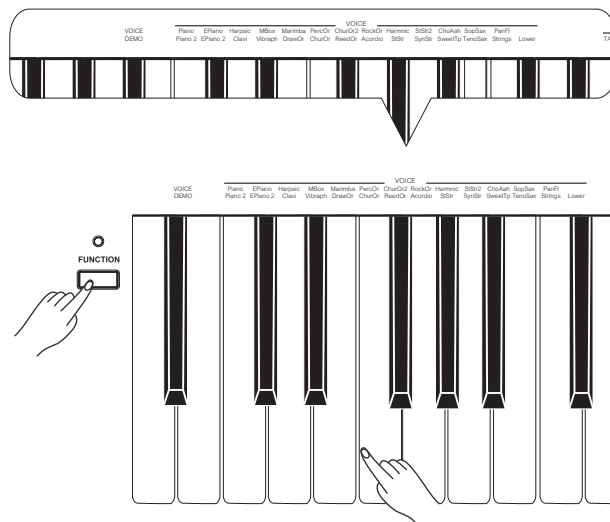

## Playing two Voice Simultaneously

You can play two voices synchronously on the keyboard by selecting a dual voice.

While holding down the [ FUNCTION ] button, press 2 keys simultaneously in voice selecting area. Press the first key to select the upper voice, press the second key to select the dual voice.

### Notes:

While dual voice is turned on, lower voice would be turned off automatically.

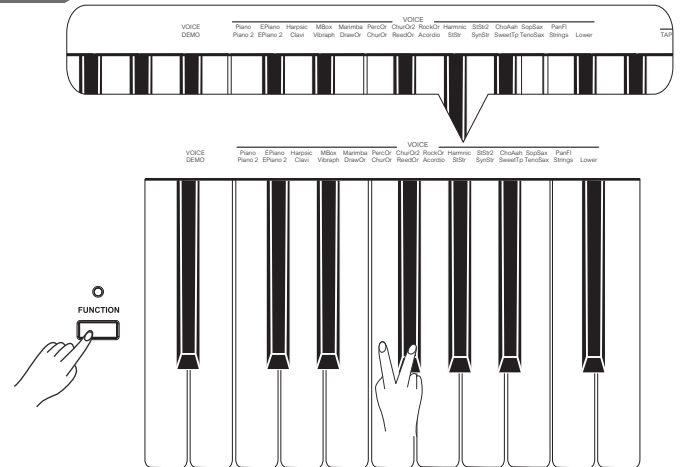

## Playing a Lower Voice

While holding down the [ FUNCTION ] button, select the Lower on the keyboard. This will select Strings as lower voice and split the keyboard at F#3 automatically.

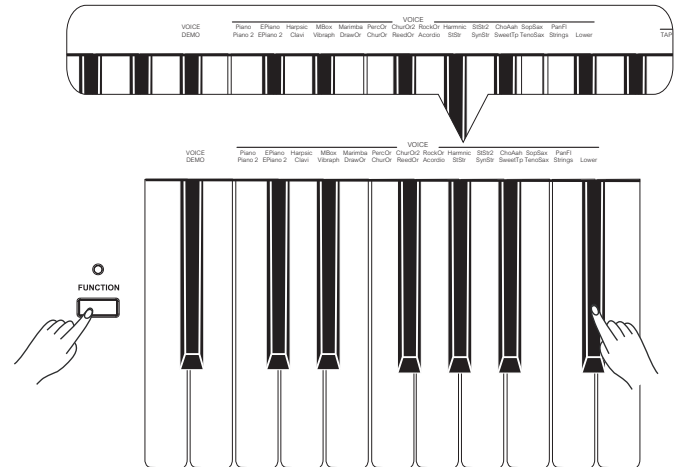
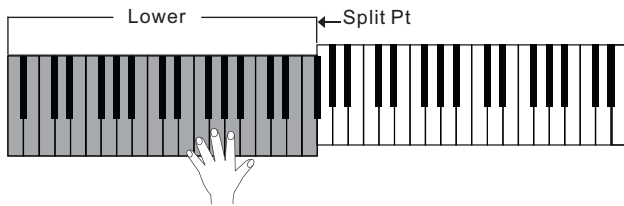

## Playing Voice Demo

While holding down the [ FUNCTION ] button, press VOICE DEMO key to start the demo for the selected voice.

Do it again to stop the voice demo playing.

This instrument contains 26 voice demos.

### NOTE:

In voice demo mode, the keyboard will be not available.

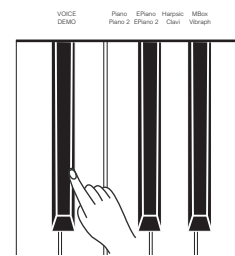

## Touch Response

While holding down the [ FUNCTION ] button, press a key in the TOUCH selecting area to select different touch response level.

- 0: OFF
- 1: Soft
- 2: Medium
- 3: Hard

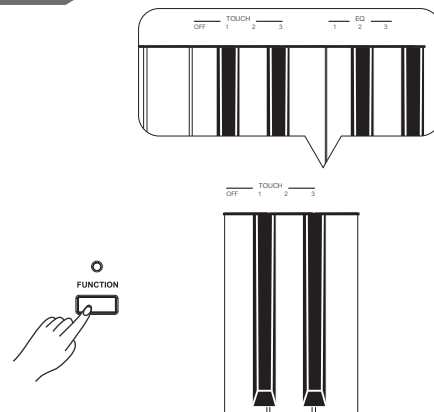

# Digital Effects

## Reverb and Chorus Effect

While holding down the [ FUNCTION ] button, press the corresponding keys in REVERB and CHORUS effect area to select the voice effect type.

Reverb Value:

- 0: OFF
- 1: Room
- 2: Small Hall
- 3: Large Hall
- 4: Stadium

Chorus Value:

- 0: OFF
- 1: Light Chorus
- 2: Medium Chorus
- 3: Deep Chorus
- 4: Flanger

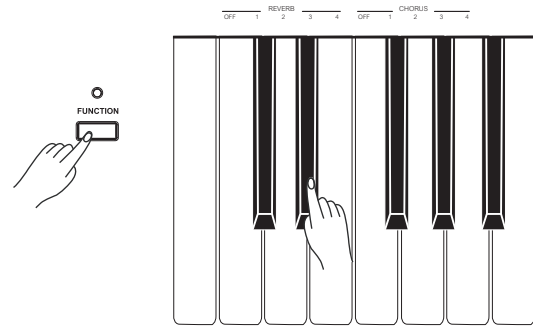

## EQ Effect

The equalizer is the function of adjusting the sound value of the gain spectrum, gain setting can bring a different sound field effect. This instrument contains 3 sets of equalizer for you to choose. While holding down the [FUNCTION] button, press the corresponding keys in EQ setting area to select the EQ type.

- EQ Type:
- 1: Standard
  - 2: Classical
  - 3: Modern

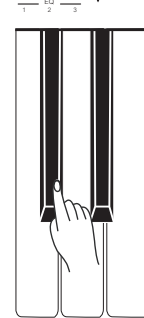
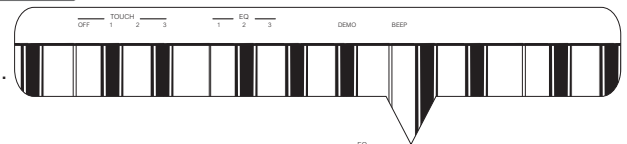

## Metronome

**Turn on the metronome:**

While holding down the [ FUNCTION ] button, press METRONOME ON/OFF key to turn the metronome ON or OFF.

**Select different time signature:**

While holding down the [ FUNCTION ] button, select a demanded time signature by pressing the corresponding keys in metronome setting area. There are 6 types of time signature: 0, 2, 3, 4, 5, 6.

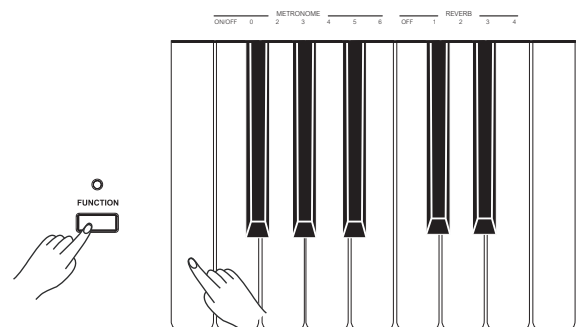
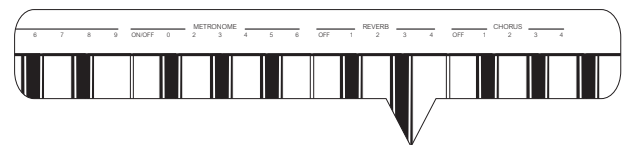

While holding down the [ FUNCTION ] button, press corresponding keys in TEMPO selection area. You can change the tempo by input number or using tap tempo, or press tempo +/- keys to change current tempo.

## Notes:

1. Press [ tempo + ] and [ tempo - ] keys simultaneously to set the tempo value back to the default (120).
2. The tempo range is :30 ~ 280
3. If you want to change tempo value by the number keys, you should input 3 numbers. For example, if you want to set the tempo value as 85, you should input "085".

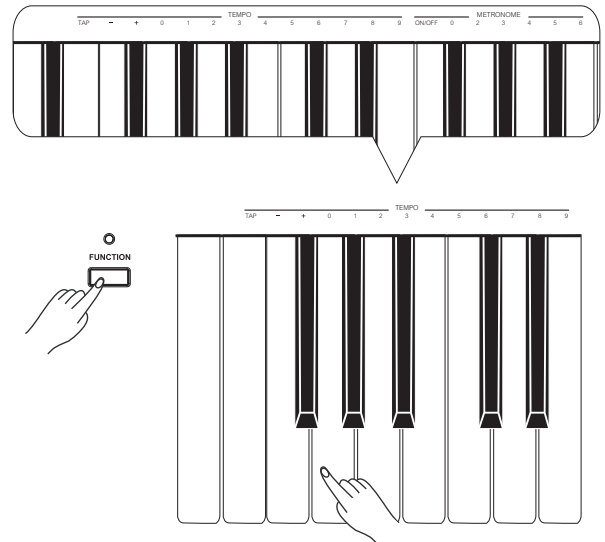

# Beep Tone

While holding down the [ FUNCTION ] button, press beep key to turn the Beep Tone ON or OFF. The default setting is ON.

If you turn on the beep tone, you can hear a beep sound when you press a valid functional key while the [ FUNCTION ] button is held down.

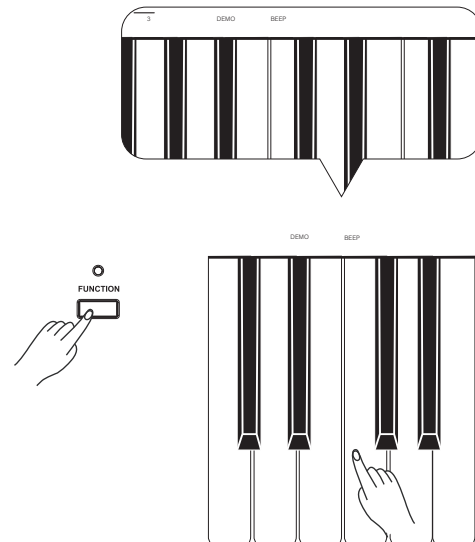

# Troubleshooting

Problem	Possible Cause and Solution
The speakers produce a “pop” sound whenever the power is turned ON or OFF.	This is normal and is no cause for alarm.
No sound when the keyboard is played.	Make sure the voice volumes are set at appropriate levels.
When using a mobile phone, noise is produced.	Using a mobile phone in close proximity to the instrument may produce interference. To prevent this, turn off the mobile phone or use it further away from the instrument.

## Specifications

### Keyboard

88 Hammer-action keys

### Polyphony

64

### Voice

26

### Demo

1

### Tempo

30-280

### Control Button

Power On/Off switch, Volume, Function.

### Control Key

Voice Demo, Voice Select Keys, Tempo Tap, Tempo +/-, Tempo Number Keys, Metronome On/Off, Metronome select keys, Reverb On/Off, Reverb Type Select Keys, Chorus On/Off, Chorus Type Select Keys, Touch On/Off, Touch Select Keys, EQ Type Select Keys, Demo, Beep.

### Connectors

DC IN, Headphones (2 standard. 1/4" phone), AUX IN, AUX OUT, USB, Pedals(Sustain, Soft, Sostenuto)

### Power Supply

DC IN

### Speaker

25W + 25W

### Dimensions

1380(W)\*485(D)\*850(H)mm

### Weight

42Kg

## Appendices

### Voice List

NO.	Full Name	Short Name
01	Grand Piano	Piano
02	Grand Piano 2	Piano 2
03	Ele.Piano	EPiano
04	Ele.Piano 2	EPiano 2
05	Harpsichord	Harpsic
06	Clavichord	Clavi
07	Music Box	MBox
08	Vibraphone	Vibraph
09	Marimba	Marimba
10	Drawbar Organ	DrawOr
11	Percussive Organ	PercOr
12	Church Oragn	ChurOr
13	Church Oragn 2	ChurOr 2

NO.	Full Name	Short Name
14	Reed Organ	ReedOr
15	Rock Organ	RockOr
16	Accordion	Acordio
17	Harmonica	Harmnic
18	Stereo Strings	StStr
19	Stereo Strings 2	StStr 2
20	Synth Strings	SynStr
21	Choir Aahs	ChoAah
22	Sweet Trumpet	SweetTp
23	Soprano Sax	SopSax
24	Tenor Sax	TenoSax
25	Pan flute	PanFl
26	Strings	Strings

# MIDI Implementation List chart

Function		Transmitted	Recognized	Remarks
Basic Channel	Default Changed	1ch 1-16ch	ALL 1-16ch	
Mode	Default Messages Altered	x x *****	3 3 x	
Note Number	Note :True voice	0—127 *****	0—127 0—127	
Velocity	Note on Note off	o 9nH,V=1-127 x (9nH,V=0)	o 9nH,V=1-127 o(9nH,V=0; 8nH,V=0-127)	
After Touch	key's Ch's	x x	x x	
Pitch Bend		x	o	
Control Change	0 1 5 6 7 10 11 64 65 66 67 80 81 91 93 120 121 123	o x x o o x x o x o o o x x o o x x o	o o o o o o o o o o o o o o o o o o	Bank Select Modulation Portamento Time Data Entry Volume Pan Expression Sustain Pedal Portamento ON/OFF Sostenuto Pedal Soft Pedal Reverb Program Chorus Program Reverb Level Chorus Level All Sound Off Reset All Controllers All Notes Off
Program Change	:true	o *****	o 0—127	
System Exclusive		x	o	
System Common	:SongPosition :Song Select :Tune	x x x	x x x	
System Real Time	:Clock :Commands	x x *1	x x *1	
Aux Messages	:LOCAL ON/OFF :All Notes Off :Active sense :Reset	x o o x	x o o o	

Notes: \*1

When the accompaniment is started, an FAH message is transmitted. When accompaniment is stopped, an FCH message is transmitted. When an FAH message is received, accompaniment is started. When an FCH message is received, accompaniment is stopped.

- Mode 1: OMNI ON, POLY
- Mode 2: OMNI ON, MONO

- Mode 3: OMNI OFF, POLY
- Mode 4: OMNI OFF, MONO

- o: YES
- x: NO

